

# Precision SAW 191.75 MHz Filter

Bandwidth 21 MHz

Part Number A018-191.75M1

Complies with Directive 2002/95/EC (RoHS)

PRELIMINARY DATA

## Typical performance

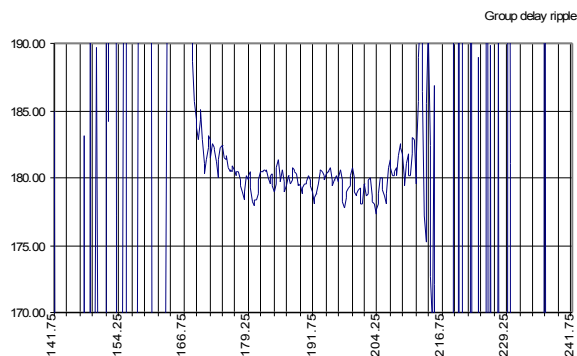
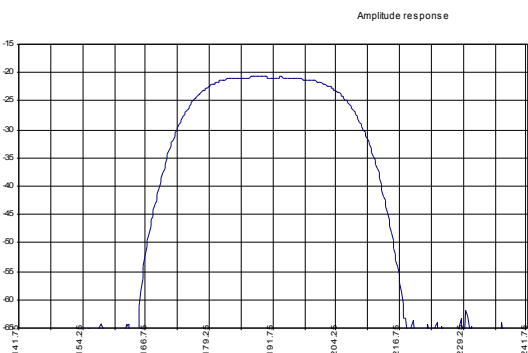

## Specifications

Parameter	Unit	Min	Typ	Max
Central frequency	MHz	191.00	191.75	192.00
Inserted loss	dB	19.5	20.5	21.5
Bandwidth @-1dB	MHz	20.00	20.75	21.50
Bandwidth @-40dB	MHz	-	51.75	-
Amplitude ripple	dB	0.3	0.5	0.7
Group Delay ripple	nsec	3	6	10
Ultimate rejection	dB	50	-	-
Substrate	-	-	128LNO	-
Temperature range	°C	-55	22	85

### Notes:

1. The design, manufacturing process, and specifications of this filter are subject to change.
2. Specification valid for measurements in AEC Design test fixture.

## Case

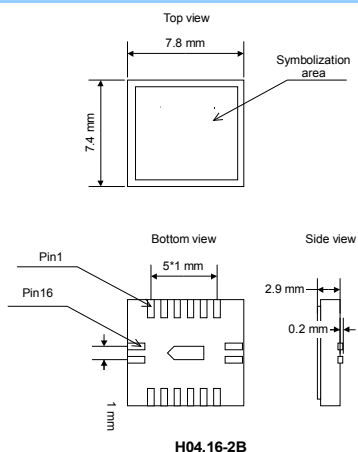

## Matching

