

Low Loss SAW 415 MHz Filter

Bandwidth 18 MHz

AEC Part Number A055-415M3

Complies with Directive 2002/95/EC (RoHS)

PRELIMINARY DATA

Typical performance

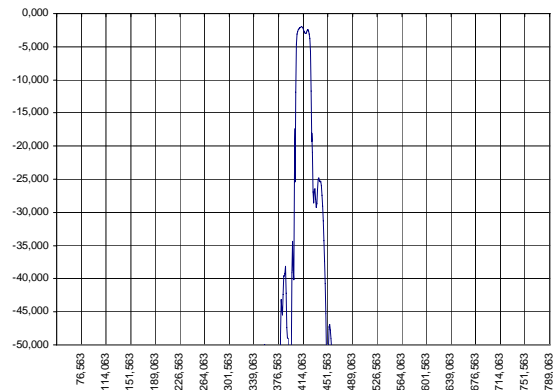
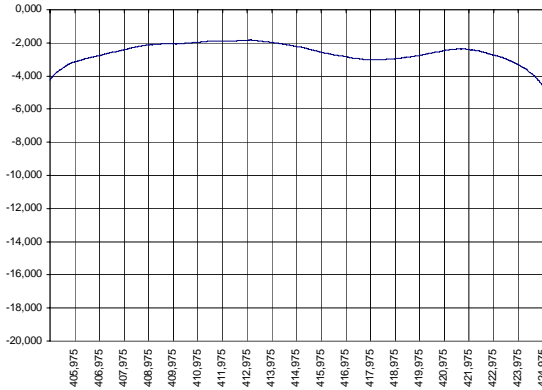

Specifications

Parameter	Unit	Min	Typ	Max
Central frequency	MHz	414.5	415.00	415.5
Inserted loss (unmatched)	dB	-	1.9	2.2
Bandwidth @-2dB	MHz	18	19.0	19.5
Bandwidth @-30dB	MHz	-	45.0	-
Amplitude ripple	dB	0.5	1	1.5
Ultimate rejection	dB	35.0	37.0	-
Substrate		-	64 LNO	-
Temperature range	°C	-55		85

Notes:

1. The design, manufacturing process, and specifications of this filter are subject to change.
2. Specification valid for measurements in AEC test fixture

Case

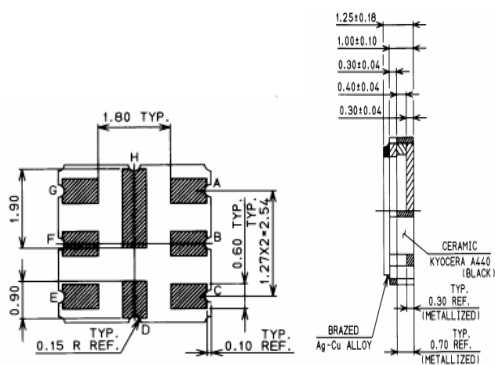

Matching

